

# Patching Old Floorboards

SPAB Technical Advice Note

Philip Hughes BSc, MRICS (Chartered Building Surveyor)  
and SPAB Scholar



The Society for the Protection of Ancient Buildings  
37 Spital Square  
London E1 6DY  
020 7377 1644  
info@spab.org.uk  
[www.spab.org.uk](http://www.spab.org.uk)

# Contents

An old floor of wide boards – scrubbed or polished for generations and uneven from wear – adds considerable richness to any room in an old building. A floor is one of the principal surfaces of a room, yet ancient boards are often badly abused. Boded attempts to replace boards are common. Even when replacement is completed satisfactorily, the result will not always be visually acceptable. In addition, replacement of floors in their entirety often takes place unnecessarily.

This Technical Advice Note aims to alleviate the problem by suggesting a number of methods by which old boards may be patched or repaired.

1	Introduction	.....	3
2	Deterioration	.....	3
3	Lifting floorboards	.....	3
4	Undulations and gaps	.....	5
5	Reducing unevenness	.....	6
6	Repairing a split board	.....	6
7	Repairing a broken edge	.....	7
8	Strengthening a weak board	.....	8
9	Splicing a broken end	.....	8
10	Relaying old boards	.....	8
11	Surface treatment	.....	9
12	Conclusion	.....	9
13	References	.....	9
14	Other advice	.....	9

**Cover image:**

Warmth and richness of a well-repaired old floor.  
Photo: Philip Hughes

# 1 Introduction

This Technical Advice Note explains common reasons why floorboards deteriorate (section 2) and a range of methods by which they can be repaired (sections 4 to 9). It also discusses techniques for successfully lifting floorboards, where it is necessary to take them up, and offers advice on their relaying (sections 3 and 10) and surface treatment (section 11).

The Advice Note is written with butt-edged boards in mind and the guidance given will not necessarily be suitable for tongued-and-grooved boards. The ancient method of fixing boards to the joists was with wooden pegs and where these or any other unusual features are found, specialist advice should be sought.

Technical terms used in this guidance are defined in our online glossary.<sup>1</sup>

# 2 Deterioration

A full examination of causes is outside the scope of this Advice Note, but the principal areas include:

- Beetle attack.
- Fungal decay.
- Careless lifting of weakened boards, particularly by electricians, plumbers and heating engineers (see figures 1(a) and (b)).
- Natural seasoning, shrinkage, and warping of boards original laid 'green'.
- The effects of furniture (especially castors) when positioned on the edge of an old board (see figure 1(c)).

It is relatively unusual to find that boards affected in any of the above ways are beyond repair (see figure 1(d)). For example, although a board may be suffering from beetle attack and have many 'worm holes' (actually beetle 'flight' holes) its strength may not have been reduced significantly.

In such a case, treatment against beetle attack **may** be all that is necessary.<sup>2</sup>

# 3 Lifting floorboards

It is extremely easy to cause serious damage to floorboards by attempting to lift them – particularly when the board is decayed. Despite the pitfalls, there are numerous techniques for lifting floorboards successfully. Lifting the first board without damage is usually much more difficult than removing the remainder. It is not an operation which should be rushed into – it requires ingenuity, preparation, care and patience! If there is an opportunity to choose which board to lift first, select with care. The ideal is a shortish board, with at least one end in relatively good condition, **not** placed against a wall, and preferably with a gap big enough for the bolster to fit between boards.

The necessary tools are likely to include: a wide-bladed bolster (preferably two of these); wooden blocks of various thicknesses; a flat hardened steel plate; a hammer; a 13 mm (½") batten about 200 mm (8") longer than the width of the board; nail punches; a hacksaw; and a crowbar.

1. Using a block of wood (or the steel plate) to protect the edge of the adjoining board, work around the board to be lifted with the bolster, levering from side to side slightly, to try to loosen the board (see figure 2(a))
2. Starting over a joist (by a nail) about a third of the way down the board (to avoid splitting the end), lever more vigorously with a pumping action first one side of the board and then the other, so as to raise the board by up to one-third of its thickness. Ensure the edge of the adjacent board is protected. Moving towards the middle, then back towards the end, repeat the process until one end of the board comes free. If this does not seem to be working or if the board is very decayed, resort to a nail punch and try to drive the nails down.
3. When one end has been freed, try placing the 13 mm (½") batten underneath it, spanning the two adjacent boards, and gradually move this towards the next set of nails with gentle pressure applied on the free part of the board (see figure 2(b)). The amount of pressure will depend on the condition of the board. This will normally ease the nails slightly out of the joists. Remove the batten and allow the board to drop to its original position to give access to the nail heads. If this does not succeed, try the bolster again or perhaps the crowbar





**Figure 1:** Damage to boards caused by: (a) and (b) Careless lifting and relaying during installation of central heating and wiring runs. (c) A castor, which can be particularly serious when the castor is positioned over the edge of a board. Softwood boards have been used inappropriately in (d) to replace a damaged wide elm board – could it have not been repaired? Photos: Philip Hughes

- levering (pump action again) under the board near the position of the nail, but away from the edge of the board.
- 4. Particular care needs to be taken with the nails at the end of the board, as it is easy to split an old board unless these are removed gently.
- 5. Once the board is free, pull out the nails – pincers, hammer or crowbar.

The levering process using the bolster against the side of the board is probably the one most likely to cause damage by bruising neighbouring boards or splitting away part of the board being lifted. This process can usually be avoided when lifting the second and subsequent boards as it is possible to place a block across the joists and to lever against the underside of the board with a crowbar (see figure 2(c)). Once the board has started to lift, the bolster or crowbar can be inserted between board and joist and levering with a pumping action resumed. Again, it is wise to start about one-third of the way along a board and work to the middle and back to the end.

Where a board (or part) is very fragile, it may be necessary to cut the nails using a hacksaw.

Ingenuity and care are the keys to success.

## 4 Undulations and gaps

It is sometimes suggested that all the floorboards should be lifted in order to shuffle them up to close gaps or to level a sloping or undulating floor. In general, such proposals should be resisted for various reasons unless there is a special need, for example, to carry out repairs. In particular, there is a danger that lifting floorboards will cause damage. Also, the undersides of many old boards are shaped because either the board or the joists are uneven, and in such circumstances they must be replaced in their original position exactly.

Deflection in a floor is often reflected by movement elsewhere in the structure, but provided that the structure is still sound it may be best to leave well alone. A levelled floor can look extremely out of place in an old cottage or house where the walls, windows and doors have deflected and where the ceiling slopes at an angle similar to that of the old floor.

Gaps between boards must be expected in an old house. Normally these will be unobtrusive and cause little problem, but where gaps approach 5 mm (1/4") or more it may be worth considering the introduction of slips of matching timber between the boards (see figure 3). This will, of course, avoid the need to lift and possibly damage the old boards. Papier mâché is also sometimes used to fill gaps between boards.

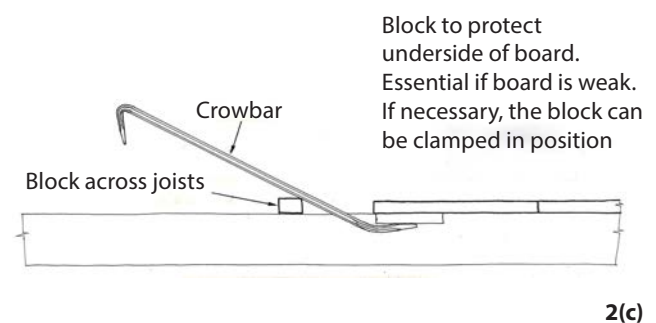
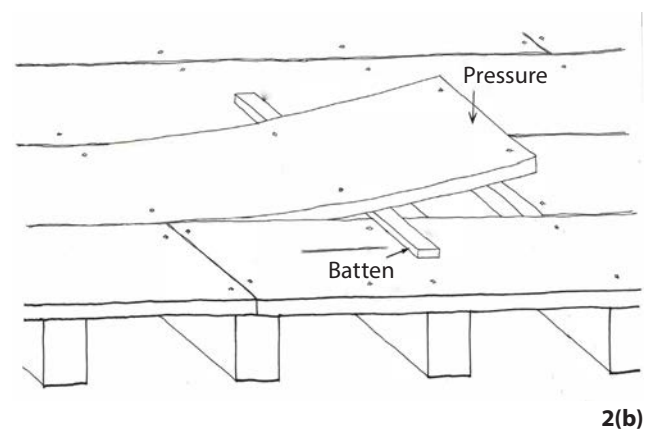
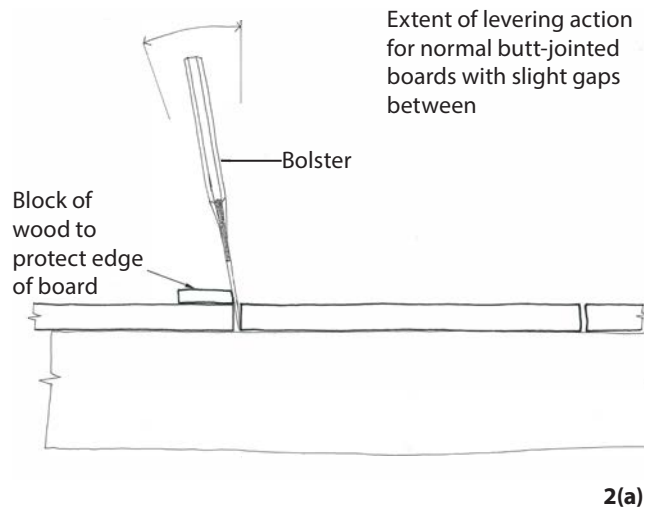

**Figure 2:** Lifting butt-edged floorboards: (a) The first stage. (b) Easing up the first board. (c) Lifting second and subsequent boards. Illustrations: Philip Hughes





**Figure 3:** Gap between floorboards filled with slip of matching timber. Photo: Philip Hughes

## 5 Reducing unevenness

An uneven board can rarely be made perfectly straight, but any twist or warp can usually be reduced to acceptable levels:

1. Lift the board.
2. Either steam the board or immerse and soak it in water. (Note: This is likely to spoil any finishes which have been applied to the board.)
3. Lay the board out to dry on battens and apply weights to overcome twisting. There is a tendency for boards to revert partially to the original twist when the weights are removed, and this should be compensated for by overweighting.
4. Allow the board to dry slowly whilst under pressure for at least one week.
5. If serious warping is still present, try applying wet rags to selected areas of the board and re-weighting. The dampened areas will swell slightly – helping to straighten a board. If it is held flat while drying, then the warping is likely to be reduced. The process can be repeated.
6. Treat the underside of the board (and joists etc, if necessary) against beetle attack.
7. Relay the old board.

## 6 Repairing a split board

### Option 1:

1. Clean out the crack/split.
2. Work glue into the split.
3. Insert wedges in joints either side to close the split while the glue is drying.
4. Insert a butterfly stitch across the crack (if required).

### Option 2:

1. Lift the board.
2. Mark the joist position on the board.
3. Clean out the crack.
4. Remove warp/twist (if necessary).
5. Glue and clamp. Ensure use of blocks to protect the edges, and that the board remains true.
6. Treat the underside of the board and the joists etc, if necessary.
7. Screw on fixing blocks but do not glue (see figure 4). If the split has been caused by maltreating the board, ensure the blocks are of similar timber to the board, well-seasoned and with grain running in same direction as that of the board. If a split has been caused by natural movement of the timber, the blocks should be fixed with slotted screw holes and with the grain running across the board.
8. Relay the board.

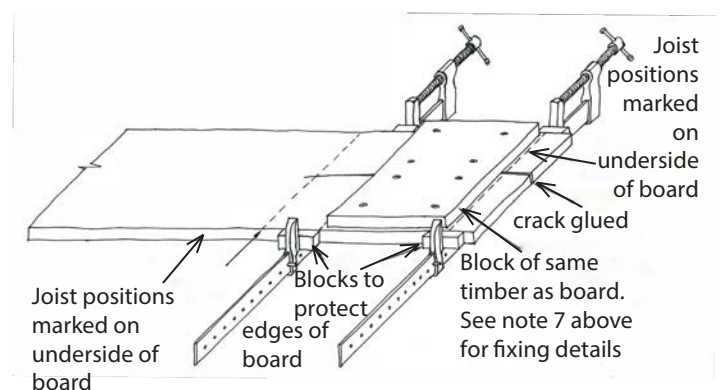

**Figure 4:** Repairing a split board. Illustration: Philip Hughes

# 7 Repairing a broken edge

1. Choose the repair type (see figures 5 and 6).
2. Lift the board (if necessary) and mark joist positions on the underside of the board.
3. Select seasoned timber of the same variety and match the grain.
4. Cut out around the broken edge of the board.
5. Form a new section to fit the old, glue and clamp in position.
6. Carefully pare down the new section to follow the undulations of the old. Do not pare down the surface or the edges of the old board.
7. Treat the underside of the board and joists etc, if necessary.
8. Relay the board (if lifted previously).

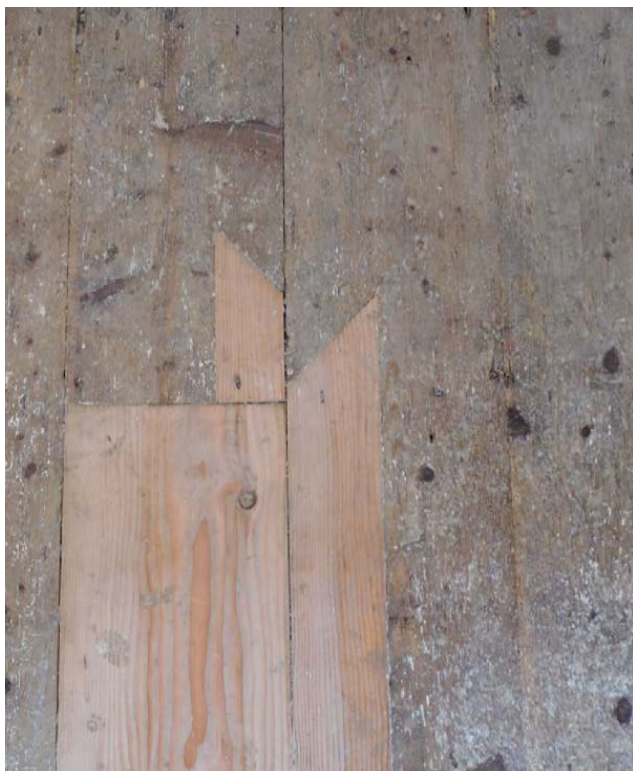

**Figure 5:** Patches of same timber variety and matching grain.  
Photo: Philip Hughes

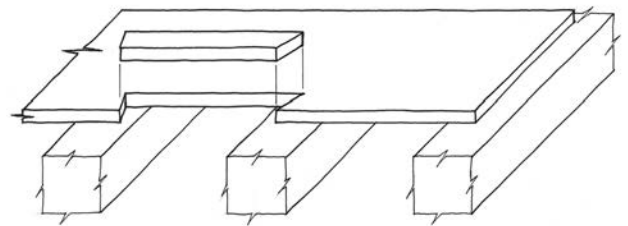

6(a)

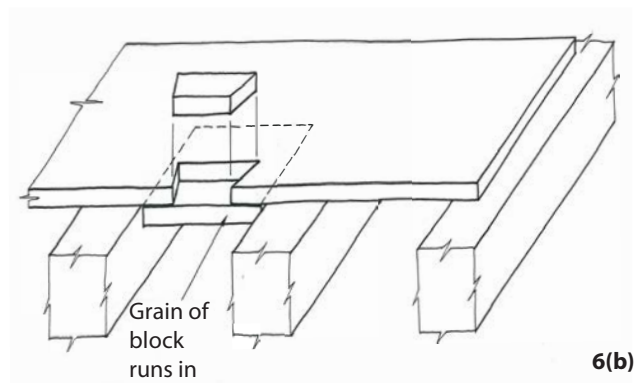

Grain of block runs in same direction as board

6(b)

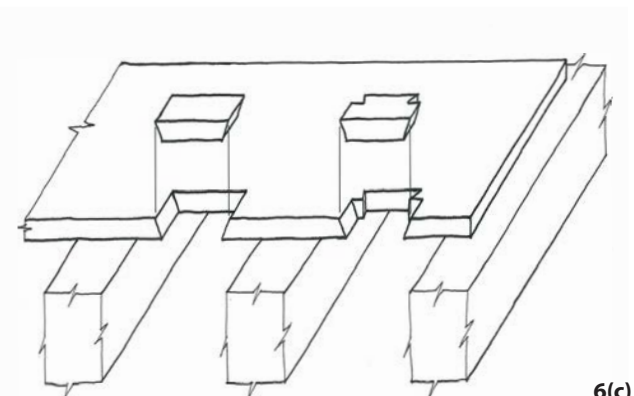

6(c)

Note: this type of splice is fairly weak but can be useful for boards at edges of floors - particularly for making good holes left by pipes etc

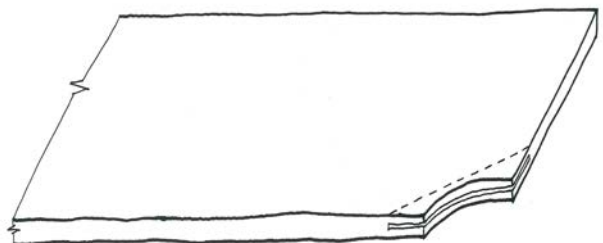

loose tongue

6(d)

**Figure 6:** Repairing a broken edge: (a) Dovetail slice with ends supported on joists. (b) Dovetail splice supported on block screwed to underside of board. (c) Tapered splices. (d) Corner insert.  
Illustrations: Philip Hughes

## 8 Strengthening a weak board

1. Lift the board (if necessary).
2. Screw battens to the sides of the joists over the area affected.
3. Lay 25 mm thick slats on battens under the weakened board (see figure 7).
4. Treat the board, slats and battens against beetle attack. Note: Treatment must be undertaken before any wax is applied.
5. Impregnate weakened areas of the board with beeswax. (If the board has become extremely fragile, it may be necessary to use resins.)
6. Relay the board.

Note: It may be necessary to strengthen or fill some areas with wood glue and sawdust – for example, around nail holes.

## 9 Splicing a broken end

If the end of a board is so decayed that it cannot be saved, then it is usual for the board to be cut back to the next joist and a short board pieced in. However, this can often mean that much more of a board is removed than is strictly necessary and, in some floors, a new short board can look completely out of place. In such circumstances it may be appropriate to splice a new end on to a board. The most appropriate type of splice to use will depend on a number of factors including the grain of the wood and the width of the board. Billiard cue jointing is sometimes used but two simpler types of splice joint are illustrated (see figure 8).

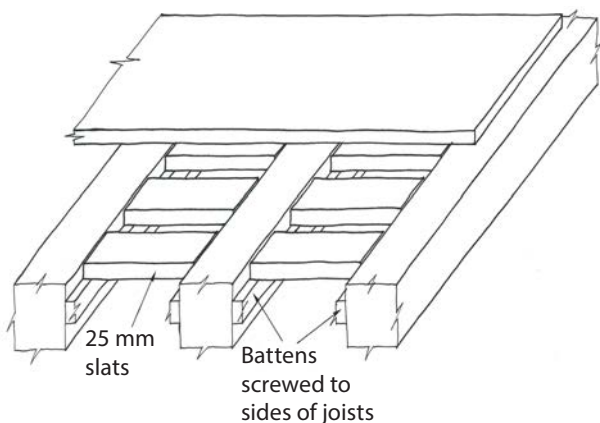

**Figure 7:** Giving additional support to a weak board.  
Illustration: Philip Hughes

## 10 Relaying old boards

Considerable care needs to be taken when relaying old floorboards. In general it is easier to nail floorboards down, but there are a number of occasions when this should be avoided, and screws used instead. For example:

1. Over a decorative plaster ceiling or ceiling painting, which might be disturbed by nailing.
2. Over a lath and plaster or reed and plaster ceiling where the plaster key is suspect.
3. Over service runs etc, where frequent lifting and relaying of the board will be necessary.

Iron screws will eventually rust and become extremely difficult to remove (even if greased). In general, brass screws should be used and these should be lightly greased before fitting to aid removal. Where a board is likely to be lifted and relaid every few years (for example, over service runs), brass cups should be used to protect the board from any damage caused by the screw head.

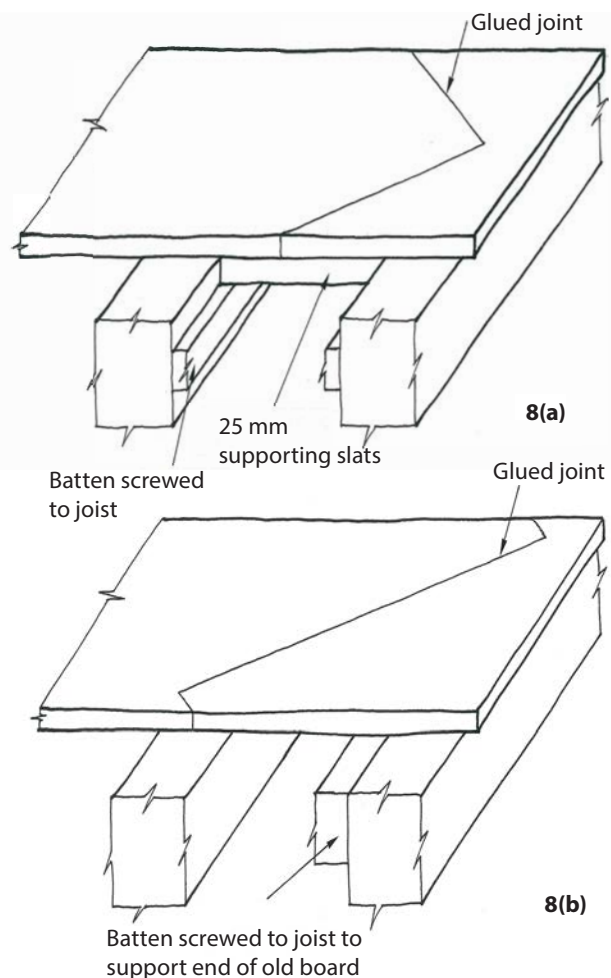

**Figure 8:** Splicing the end of a board at the edge of a floor (a) and (b).  
Illustration: Philip Hughes



Where walls may be damp, keep the edge board slightly away from the wall to reduce the risk of decay.

Avoid placing fixings under the front edge of any skirting. This avoids the need for the skirting to be disturbed if the board needs to be lifted again.

## 11 Surface treatment

This is really a suitable subject for an Advice Note on its own, but it is perhaps worth mentioning a few points here.

Old boards should never be sanded. If a board has suffered at all from beetle attack, sanding will remove the smooth surface of the board and leave a ragged mess of 'worm-ridden' timber beneath.

If it is necessary to remove a paint, stain or varnish on the surface of the board, reference should be made to SPAB Information Sheet 5 on *Removing Paint from Old Buildings*.<sup>3</sup> Stains will have soaked into the surface of the timber, and although poulticing may reduce the effect of the stain, it is unlikely to remove it entirely. Repeated poulticing may help.

In general, old boards that have not been polished will have been scrubbed. Minimum water should be used when scrubbing boards. If the board has suffered from beetle attack in the past, scrubbing may remove the surface in the same way as sanding. In such cases, it is probably best to treat the board with timber preservative and then polish with beeswax – trying to get this to soak into the board to consolidate the weakened timber surface.

Before polishing boards, thought should be given to the serious danger of slipping. Loose rugs should never be laid over polished floors.

Modern varnishes and finishes should be avoided, as they tend to give an unsympathetic appearance. Linseed oil should also be avoided as it is slightly sticky, attracts the dirt and darkens with age.

## 12 Conclusion

As one of the principal surfaces of a room, the overall treatment of a floor needs to be carefully considered in relation to: the appearance of the room as a whole; the context of the building; and the function of the floor. Simple straightforward repair of existing floorboards, as described in this Technical Advice Note, should substantially enhance the quality and appearance of the interior of the building. When repairs have been well-executed, there should not normally be any need to try to tone them in, as they will demonstrate the care and craftsmanship that has been lavished on the building.

## 13 References

1 See <https://www.spab.org.uk/advice/glossary>

2 For more about dealing with timber decay, see SPAB Information Sheet 14 by Richard Oxley on *Is Timber Treatment Always Necessary? An Introduction for Homeowners*

3 For more about paint stripping, see SPAB Information Sheet 5 by Adela Wright on *Removing Paint from Old Buildings*

## 14 Other advice

### 14.1 Contacts

Where work to old floorboards is being considered, the SPAB may be able to suggest suitable specialists, including contractors.

### 14.2 Further reading

English Heritage (2012) *Timber*, Practical Building Conservation, Farnham: Ashgate Publishing Ltd

Oxley, R (1999) *Is Timber Treatment Always Necessary? An Introduction for Homeowners*, SPAB Information Sheet 14, London: Society for the Protection of Ancient Buildings

Schofield, J (1997) *Beeswax Polish*, SPAB Information Sheet 13, London: Society for the Protection of Ancient Buildings

Slocombe, M (2017) *The SPAB Approach to the Conservation and Repair of Old Buildings*, London: Society for the Protection of Ancient Buildings

The content of this publication is offered in good faith, but neither the author nor the Society can accept responsibility arising from incorrect or incomplete information that may be included. The use of traditional materials may incur risks that are different from those associated with modern materials. Manufacturers' and suppliers' guidelines should always be observed. This document is intended as a contribution to a continuing debate and we welcome comments.

Written by Philip Hughes. This publication revises and supersedes our former Information Sheet 10 (1st edition, 1988). The author is indebted to Dr Joseph Bispham and Ben Hornberger for their help with the preparation of this revised edition. Grateful thanks to Judith Rodden for editorial advice. Produced by Catherine Peacock. The sources of illustrations are given adjacent to them together with any copyright where not belonging to the SPAB.

The Society for the Protection of Ancient Buildings (SPAB) believes old buildings have a future. From cottages to castles and from churches to cathedrals we are here to help buildings and the people who care for them. Through our unique training schemes, courses, advice and research we help people put our expertise into practice.

Today the SPAB encourages excellence in new repair and good design to enrich and complement the built historic environment. We train new generations of architectural professionals and building craftspeople to conserve this landscape with sensitivity and skill, and we play a statutory role as adviser to local planning authorities. In our casework we campaign actively to protect old buildings at risk.

SPAB: hands on history. Join today to support our positive, practical approach to building conservation.



Published by the SPAB  
in October 2019  
© SPAB 2019 Edn 2 Rev 0

SPAB ref T5302M  
[www.spab.org.uk](http://www.spab.org.uk)

ISBN 978-1-898856-38-2

The Society for the Protection of Ancient Buildings  
37 Spital Square, London E1 6DY  
Tel 020 7377 1644

[info@spab.org.uk](mailto:info@spab.org.uk) [www.spab.org.uk](http://www.spab.org.uk)

A charitable company limited by guarantee  
registered in England and Wales

Company No 5743962 Charity No 111 3753 VAT No 577 4276 02